



Assembly Instructions
Model: ECC76

- ___ (1) Seat
- ___ (1) Back
- ___ (2) Front legs
- ___ (2) Back legs
- ___ (2) Mid legs
- ___ (2) Arms
- ___ (3) Braces
- ___ (1) Hardware pack

TOOLS NEEDED

Phillips head screwdriver

Step 1

Lay seat on its side. Attach legs to seat.
Now flip seat around and do the other side.
Uses (16) 1½" screws

Step 2

Attach braces to legs
using (6) 1½" screws

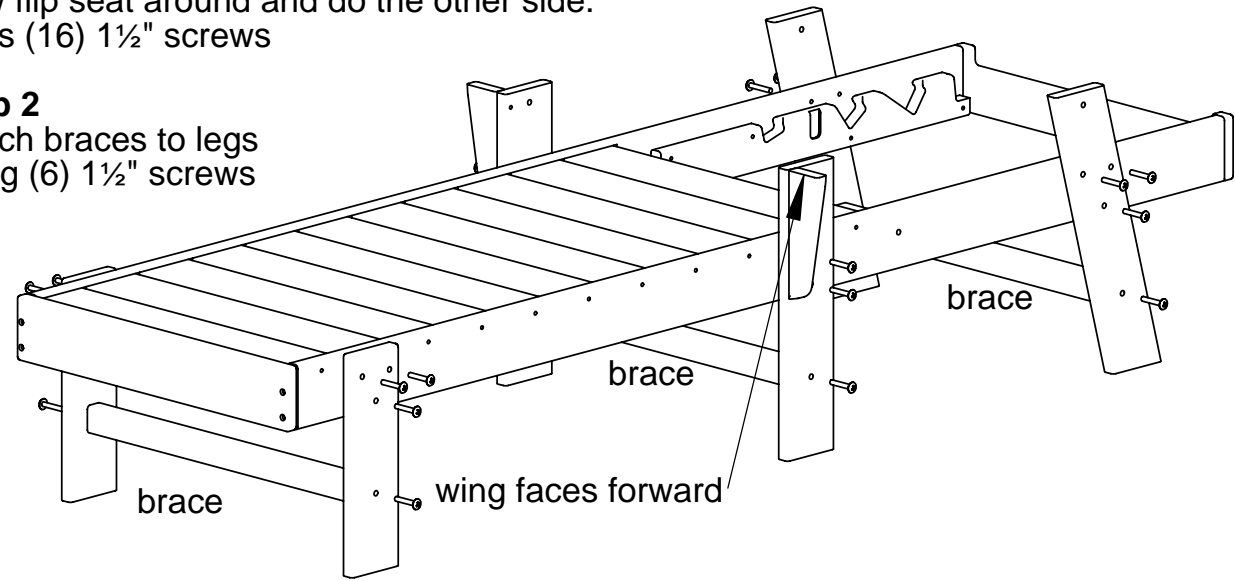

Step 3

Attach arms to legs
using (4) 1½" screws

Step 4

Attach back to seat
using (2) 1½" screws

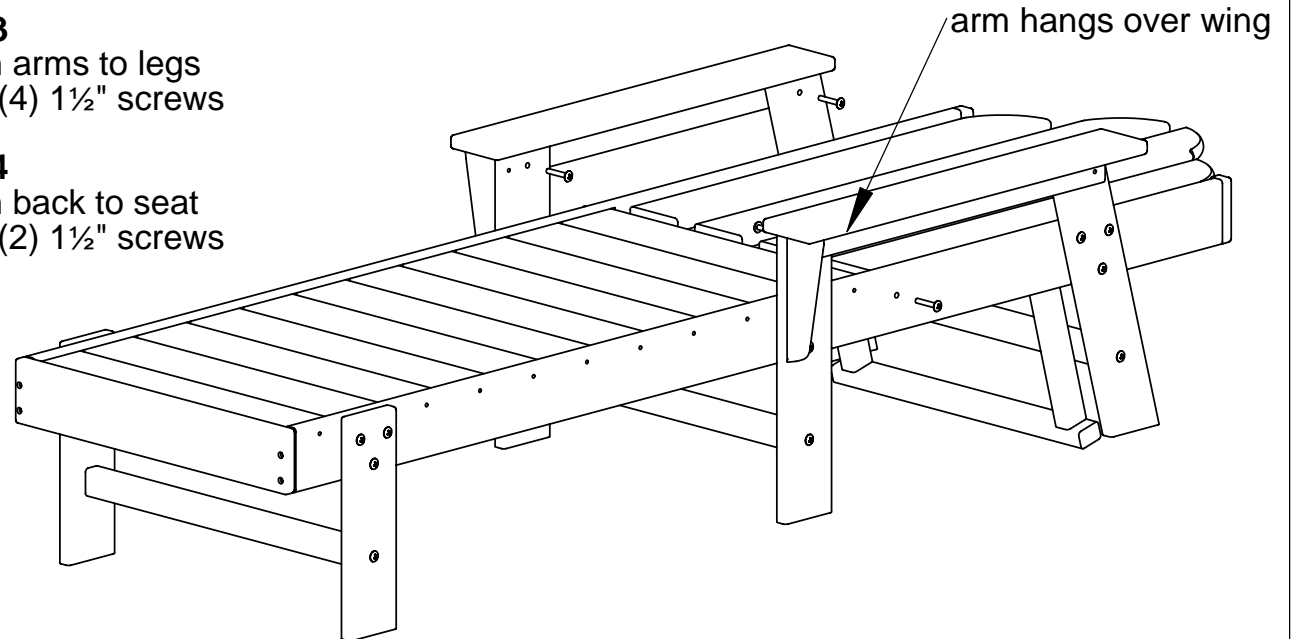

Qty.	Description
28	A - 14x1½" Screw

All screws are truss head type B All hardware is SS